

# User Manual

## Polaris Lithium Series





## INDEX

1.	General aspects of the battery.	1
a.	Composition.	1
b.	Configuration of the charger with the battery.	1
2.	Declaration of conformity.	3
3.	Security.	4
4.	Information on composition	5
5.	First-aid measures in case of exposure to internal battery components.	5
6.	Measures in case of fire.	6
7.	Accidental release measures.	7
8.	Use of personal protective equipment.	8
a.	Under normal conditions.	8
b.	After an incident.	8
9.	Stability and reactivity.	8
10.	Toxicological information.	9
11.	Procedure for disposal of lithium-ion batteries.	9
12.	Transport information.	9
a.	General.	9
13.	Battery specifications.	10
a.	Battery components.	10
14.	Battery types.	11
15.	Labelling.	11
16.	Installation.	12
17.	Manipulation.	12
18.	Start up.	13
a.	S-BMS Model.	15
b.	C-BMS Model.	16
19.	Connecting the display.	16
a.	Operation.	16
b.	Icons.	17
c.	Wifi hotspot configuration.	17

d.	Data verification.	18
20.	Charge.	19
21.	Storage.	19
22.	Maintenance.	21
a.	Preventive.	21
i.	Maintenance procedure.	21
		21
ii.	Mode of protection.	21
b.	Corrective.	22
23.	Repairs.	23
24.	Warrenty.	23

## 1. General aspects of the battery.



**Keep the instructions for future reference and the manual within easy reach of anyone who will be using the battery. the battery. Installation may only be carried out by Endurance Motive S.A. authorised personnel.**

### ATTENTION

#### a. Composition.

The energy storage of our Polaris Lithium batteries is based on Lithium Ferrophosphate (LiFePO<sub>4</sub>) cells, certified by UN38.3/MSDS, RoHS, CE, TUV and UL with high safety. The cell cover material is flame retardant and has a ceramic diaphragm pressure valve for increased safety.

It also has a BMS (battery management system) that provides intelligent action for charging, discharging and monitoring.

The BMS monitors that limit values are respected, and in case of malpractice, protects the battery against critical conditions.

Our batteries are designed for electric forklift trucks and material handling equipment for indoor use.

It has its own IP65 steel enclosure designed to withstand the temperatures and pressures encountered during normal use.

It is delivered with the ballasted case, designed for a specific forklift truck model, which complies with the forklift truck manufacturer's recommendations.



**CARE**

**The Polaris Lithium battery is designed for a specific model of forklift truck and should not be used in other models.**

#### b. Configuration of the charger with the battery.

The batteries mentioned in this manual are supplied together with a CAN charger, which are pre-configured.

A specific charger supplied by Endurance Motive S.A. must be used for charging which, in turn, will be controlled from the Polaris Lithium battery via the CAN interface.

If you own or purchase a charger with CAN Bus communication protocol, there should be no incompatibility, as long as the CAN Bus standard between the battery and the charger is respected

In case of incompatibility and/or problems, Endurance Motive S.A. will be able to provide information on the communication protocol used.

In general, the capacity demand of a lithium-ion battery is lower than that of an equivalent lead-acid battery. This is because it has fewer losses.



## 2. Declaration of conformity.

**Maker:**Endurance Motive SA

**Address:**C/ La Bernia 1, 46529 Canet de Berenguer - Valencia – Spain

Endurance Motive SA declares that the list of products indicated below complies with the relevant European Union legislation on harmonization and bears the CE marking in accordance with the following directives:

Electromagnetic Compatibility (EMC) 2014/30/EU  
RoHS Directive 2011/65/EU  
Low Voltage Directive 2014/35/EU  
Product safety device 2001/95/CE  
Directive 2006/66/EC Including your amendments

References to the relevant harmonized standards used or references to other technical specifications against which conformity is declared:

UNE-EN 62619:2017  
IEC62620:2014  
IEC62133:2012  
EN 61000-6-3:2007 + A1:2011

**Kind of team:**

Battery with external charger.

**Kind of product:**

PL24V (100-700Ah)  
PL48V (200-1000Ah)  
PL80V (300-1500Ah)

Carlos Navarro (CEO)

Date: 02-01-2023

### 3. Security.



**The Polaris Lithium battery system is non-hazardous when used in accordance with the recommendations in this manual. All staff must receive adequate information and training on the correct use and operation of these.**

#### **ATTENTION**

Please note the following warnings before using the battery.

- The Polaris Lithium battery must only be used in the appropriate forklift truck, with the weight and voltage described on the label and in accordance with the forklift truck manufacturer's requirements. Improper use may result in damage to both the forklift truck and the user of the forklift truck.
- Do not use the Polaris Lithium battery if it is damaged. Do not handle damaged parts and contact Endurance Motive S.A. service personnel.
- Use extreme caution when handling the external battery connection cables to avoid short circuits between the external battery terminals and the contacts. A short circuit can cause fire, property damage and serious injury.
- The external connector is designed to mate with the machine and charger in the correct way; therefore, avoid:
  - Forcing the connections.
  - Removing the connector by pulling on the cable.
  - Tampering with the connector by unauthorised personnel.
  - Because it has an IP21 degree of protection, it must not get wet.
- The Polaris Lithium battery must only be connected to the appropriate charger that has been configured for charging the Polaris Lithium battery. Do not use any other charger, as this may damage the Polaris Lithium battery and/or cause injury.
- Do not stand or lean on the Polaris Lithium battery.
- Do not open the Polaris Lithium battery to gain access to the interior.
- Use only the cables supplied by Endurance Motive S.A. In the event of damage to the cables, replacement cables must be ordered from Endurance Motive S.A.
- Only authorised personnel must carry out the installation or removal of the battery.
- The product must not be disassembled.



**DANGER**

**Do not short-circuit, puncture, incinerate, crush, immerse in water or expose to temperatures outside the range specified by the manufacturer. If this occurs, electrolyte leakage, explosion or fire of the battery may occur, depending on the circumstances. In the event of a prolonged short-circuit, the battery may reach high temperatures, emitting gases and a fire may be generated.**



**ATTENTION**

**Any damage to the battery caused by the actions described above will invalidate the use of the warranty.**



If, due to external influences such as violence, fire, flooding, etc., it is not possible to operate the system safely. In case of irregular phenomena, the following must be taken into account:

- The cells contain substances that are flammable when they reach the oxygen in the air.
- The cells contain substances that can form a flammable mixture with the air after evaporation.
- Cells contain substances that can react with water as soon as they reach the humidity in the air or if water enters a cell.
- These substances can be expelled if a cell is exposed to high pressure or external fire, or if it is damaged by mechanical force.
- The amount of these substances is so small that caution should only be exercised in the immediate vicinity of the energy system.

#### 4. Information on composition

The battery consists of a metal casing containing several sealed cells of lithium-ion phosphate and other materials, which could be potentially hazardous if released.

SUBSTANCE	INDEX ca. %	CAS-Nr.
LITHIUM IRON PHOSPHATE	49,0	15365-14-7
ALUMINIUM	6,0	7429-90-5
GRAFITO	24,0	7782-42-5
COPPER WIRE	13,0	7440-50-8
LITHIUM HEXAFLUOROPHOSPHATE	3,0	21324-40-3
POLYPROPYLENE	5	9003-07-0

#### 5. First-aid measures in case of exposure to internal battery components.

Lithium-ion batteries contain compounds of lithium salts, organic solvents, etc. If used improperly or in extreme environments, dangerous situations such as leakage, smoke, overheating and opening of the safety valve (with spraying of black substance), fire may occur. To protect the safety of personnel and reduce economic losses, you must take urgent protective measures in case of danger.



**Please read and carefully observe the following protection recommendations:**

<b>SMOKE INHALATION</b>	When smoke is present, use protective measures (such as covering your nose and mouth with a wet towel or wearing a professional gas mask) to prevent smoke inhalation. Since smoke and other noxious gases can damage the respiratory system, administer oxygen if necessary. Move the victim to fresh air and remove the source of contamination from the area. In severe cases, seek medical treatment.
<b>EYE CONTACT</b>	Rinse immediately with plenty of water for at least 15 minutes, lifting the upper eyelid while rinsing. Rinse with saline solution if possible. In severe cases, seek medical treatment.
<b>SKIN CONTACT</b>	Remove any clothing you are wearing, wash thoroughly with water. Seek medical treatment in severe cases.
<b>INGESTIÓN</b>	Drink milk/water and induce vomiting; seek medical care.

## 6. Measures in case of fire.

<b>GENERAL DANGER</b>	<p>A destructive impact can cause the battery to release internal energy in an instant, causing a pressure release of the safety valve, smoke, etc.</p> <p>At temperatures above 120°C, the pressure valve may burst and flammable gases may escape.</p> <p>At this point, fire extinguishing measures must be taken.</p>
<b>LIGHT or LARGE FIRE</b>	<p>In case of fire, flames or smoke:</p> <ul style="list-style-type: none"> <li>▪ while driving: stop, turn off the truck and leave the area</li> <li>▪ During charging: stop the charger or remove the charging cable and leave the area.</li> <li>▪ Move the power system outdoors or to a well-ventilated area and move people away from the area when possible.</li> <li>▪ Establish a 5 metre safety perimeter around the battery</li> <li>▪ Use extinguishing systems to isolate the system from the air such as masking sand, carbon dioxide or dry powder</li> </ul>

	<p>extinguishers or other extinguishers, and disconnect the system at the same time. Avoid using water as it may produce hydrogen fluoride.</p> <ul style="list-style-type: none"> <li>▪ Call the emergency services and report that the fire has been caused by a Lithium Ion battery.</li> </ul>
--	--



**DANGER**

**After extinguishing the fire, do not use the battery again. Contact the after-sales service department.**

## 7. Accidental release measures.

<b>MEASURES TO BE TAKEN IN THE EVENT OF SPILLAGE OR LEAKAGE OF MATERIALS</b>	<ul style="list-style-type: none"> <li>▪ If material is released from the battery, remove personnel from the area until fumes dissipate.</li> <li>▪ Provide maximum ventilation to remove hazardous fumes.</li> <li>▪ Leave area and allow batteries to cool and vapours to dissipate.</li> <li>▪ Avoid contact with skin and eyes or inhalation of vapours. Remove spilled liquid with a cloth, then dispose of in a plastic bag and place in a steel box.</li> </ul>
--	--



**DANGER**

**Batteries must not be opened, destroyed or set on fire, as they may leak or rupture and release the ingredients contained in the hermetically sealed container into the environment.**

<b>MANIPULATION</b>	<ul style="list-style-type: none"> <li>▪ No special protective clothing is required for handling.</li> <li>▪</li> <li>▪ The battery must be transported in its original packaging or equivalent. The battery system must not be opened, destroyed or set on fire.</li> <li>▪ Follow the manufacturer's recommendations for maximum recommended currents and operating temperature range using a dedicated charger.</li> </ul>
---------------------	---

## 8. Use of personal protective equipment.

### a. Under normal conditions.

<b>RESPIRATORY PROTECTION</b>	Not necessary under normal conditions of use.
<b>PROTECTIVE GLOVES</b>	Not necessary under normal conditions of use.
<b>EYE PROTECTION</b>	Not necessary under normal conditions of use.
<b>OTHER CLOTHING</b>	Not necessary under normal conditions of use.

### b. After an incident.

<b>RESPIRATORY PROTECTION</b>	In the event of battery failure, provide as much ventilation as possible. Avoid confined areas where batteries are vented.
<b>PROTECTIVE GLOVES</b>	Use polypropylene, polyethylene, rubber or Viton gloves when handling broken or leaking items.
<b>EYE PROTECTION</b>	Wear safety goggles with side shields or a full face mask when handling broken or leaking items.
<b>OTHER CLOTHING</b>	Wear a rubber apron and protective clothing when handling broken or leaking items.

## 9. Stability and reactivity.

<b>REACTIVITY</b>	None, beyond normal conditions
<b>CONDITIONS TO AVOID</b>	Heating, mechanical and electrical abuse
<b>MATERIALS TO AVOID</b>	None, beyond normal conditions
<b>HAZARDOUS DECOMPOSITION PRODUCTS</b>	None, beyond normal conditions

## 10. Toxicological information.

Inhalation, skin and eye contact is possible when the battery is open. If exposed to internal contents, corrosive vapours will be very irritating to skin, eyes and mucous membranes. Overexposure may cause symptoms of non-fibrous lung damage and membrane irritation.

## 11. Procedure for disposal of lithium-ion batteries.

- Before disposal make sure that the battery is fully discharged.
- Batteries must be neutralised by an authorised secondary treatment facility before disposal as hazardous waste.
- Recycling of batteries can be done at an authorised facility through an authorised waste carrier.
- Batteries must be returned to the manufacturer or recycled in accordance with the environmental regulations and recycling laws of the country concerned.
- Cell identification according to IEC 62620: ICNMP/28/149/95/H/-30+55/95.
- Please note that the Polaris Lithium battery must be treated as dangerous goods in accordance with UN3480, Class 9 during transport. External terminals must be protected against short circuits.
- Batteries, whether normal or expired, must be packed in accordance with P903.
- The packaging and marking of the goods must only be carried out by personnel trained in the transport of dangerous goods (training 1.3, according to UN 38.3).

## 12. Transport information.

### a. General.

If the watt-hour capacity of the battery exceeds 100Wh, this lithium-ion battery must be declared and shipped as "Class 9" DANGEROUS GOODS. According to IATA DGR Packing Instruction 965 (UN 3480) or 966/967 (UN 3481), IATA DGR Section I - Fully Regulated Class 9 Lithium-ion Cells and Batteries - and ADR Packing Instruction P903 and the IMDG Code. The "Class 9" dangerous goods label is required.

<b>Codes and classification according to international transport standards</b>		
Air	IATA/CAD	UN 3480
Maritime	IMDG	UN 3480
Land	ADR/RID	UN 3480

### 13. Battery specifications.

#### Battery components.

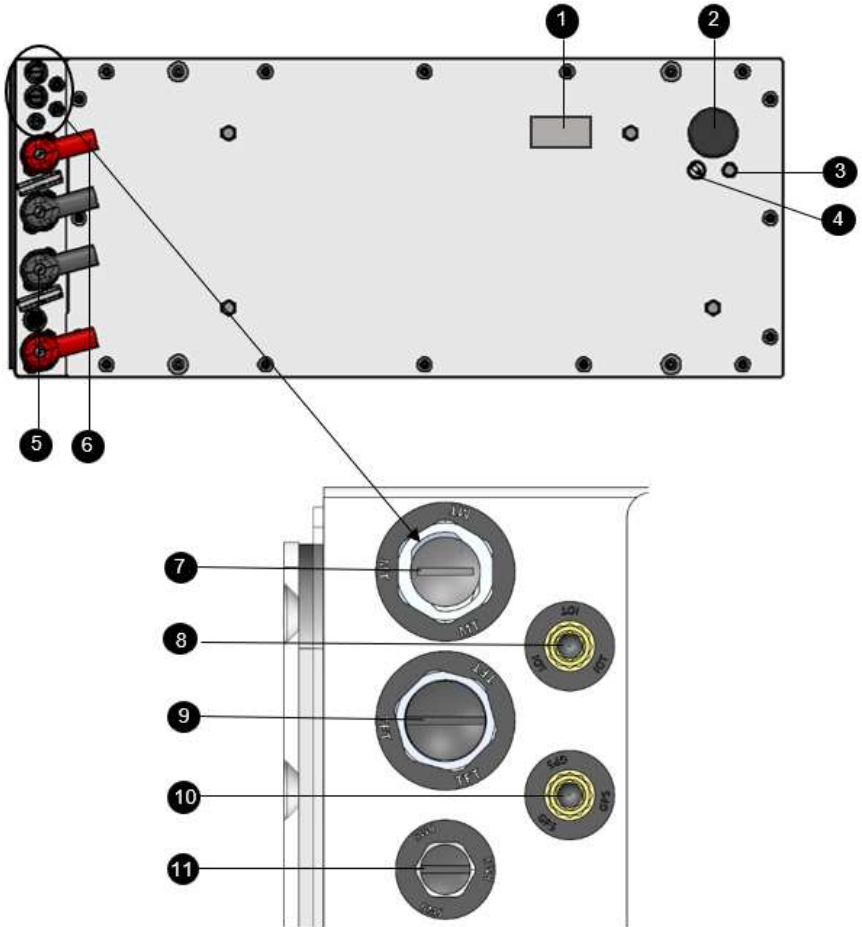

1. Technical data label on the battery.
2. Battery charge status indicator display.
3. Battery power button.
4. Battery off switch.
5. Battery connector to charger.
6. Battery connector to machine.
7. Turtle mode connector.
8. IOT connector.
9. TFT Display Connector.
10. GRPS connector.
11. BMS connector.

## 14. Battery types.

Nominal Energy	25,6V	38,4V	51,2V	73,6V	83,2V	96,0V	121,6V
Measures	On demand						
Cell composition	Lithium / Iron Phosphate						
Operating temperature	-30°C à 55°C (no cold storage longer than 5h)						
Operating temperature under load	0 °C à 45 °C						
IP Protection	IP65						
DOD Life Cycles 70%	4.000						
Charging period	>1h						

## 15. Labelling.



### Warning Signal.

Danger: The battery contains cells. Avoid short-circuit.



### Prohibition Sign.

Do not expose the battery to high temperatures. The Polaris Lithium battery is designed for use at ambient temperatures up to +45 °C. For safety reasons, the battery should not be exposed to temperatures above +85 °C.



### Information signal.

Read the user manual before installing and using the Polaris Lithium battery.

### Recycle bin crossed out.

This product must be properly recycled.

1

<b>Lithium</b> Energy System		Polaris Lithium 24V 300Ah Ref: PL24V300CB- S NS: EM10619A101	
<span style="border: 1px solid black; border-radius: 50%; padding: 2px 6px;">2</span> V Nom: 24V Cap. Nom : 300Ah Energia: 7.680 Wh Tª de uso: De - 10°C a + 55°C Tª de carga: De 0°C a + 45°C Protección IP: IP21 Peso: 372 Kg		<span style="border: 1px solid black; border-radius: 50%; padding: 2px 6px;">3</span> Dirección: C / En proyecto, N8, Sector 10. 46393- LORIGUILLA- VALENCIA- SPAIN <a href="http://www.endurancemotive.com">www.endurancemotive.com</a>	
<b>Advertencias de seguridad:</b> No golpee la batería. Evitar un cortocircuito. No abra la batería para acceder al interior. No exponer la batería a temperaturas superiores a + 85°C. Lea el manual de usuario antes de utilizar la batería			

1. Model, internal reference and serial number.
2. Battery specifications.
3. Warning symbology, company information and safety warnings.

## **16. Installation.**

The battery must be installed by authorised personnel. Check that the safety conditions of the installation are complied with.

## **17. Manipulation.**

Use the corresponding holes and lifting equipment that exerts pressure towards the vertical load at the fixing points. The lifting system varies depending on the battery model. The position of the fixing holes may vary depending on the battery model.



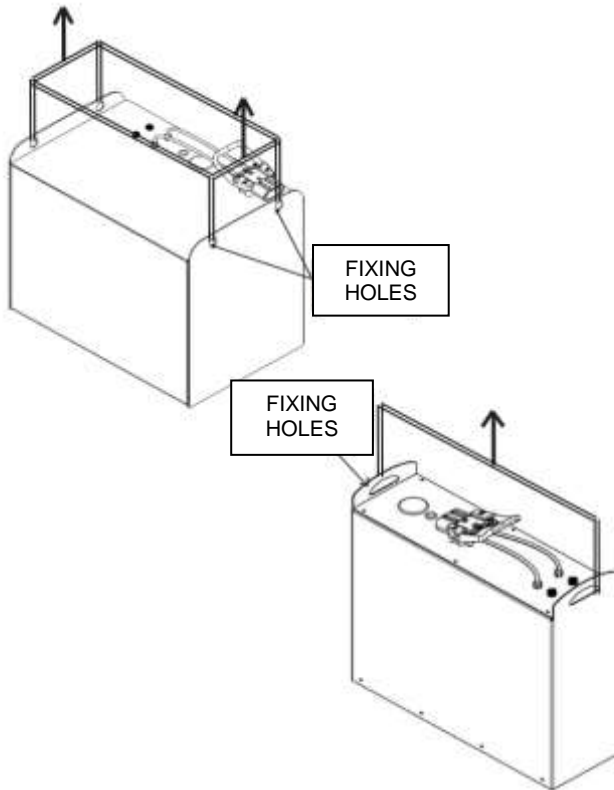

## 18. Start up.

To start the Polaris Lithium battery, press the battery power button on the top of the housing for two (2) seconds. Once pressed, the battery will turn on and you will hear the sound produced by the activation of the battery's internal disconnectors. The battery is now ready for use.

The Polaris Lithium battery is delivered at approximately 30% charge. In order to guarantee the correct balancing of the battery, it is mandatory that before the first use, a first full balancing charge lasting up to 48 hours is carried out. After the first full charge the battery can be used.

After the first full charge it is normal to observe that the SOC does not reach 100%. As soon as it is possible, perform a second full swing charge lasting up to 48h, this will balance to a SOC of 100% within the first two weeks of use.

Translated with [www.DeepL.com/Translator](http://www.DeepL.com/Translator) (free version)

To protect against discharging, the Polaris Lithium battery is equipped with a control system called "Auto-Off". The "Auto-Off" system will disconnect the internal contactors and turn off the battery when one hour (1 h) has elapsed since the last use.



**ATTENTION**

**Battery shutdown differs depending on the battery model.  
The model you have purchased is specified on the cover of  
your user manual.**

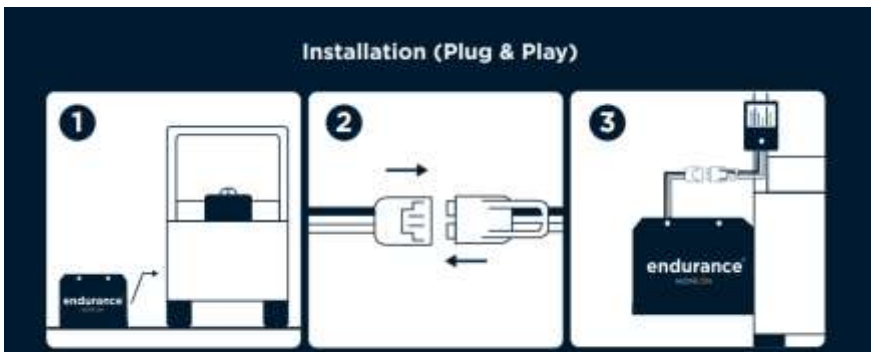

**a. S-BMS Model.**

If your battery is the S -BMS model, there is no switch-off switch, as the battery is automatically switched off by the "Auto-Off" system.

## b. C-BMS Model.

If your battery is the C-BMS model, the battery is switched off by pressing the same power switch for 2 seconds.

After the 2 seconds have elapsed, release the on/off button and the battery will switch off.

## 19. Connecting the display.

To switch on the display, connect the plug connector at the end of the cable to the receiver connector on the battery housing. Press the button on the front of the device for one second until the battery starts to operate. The TFT screen will then light up.



## a. Operation.

When the TFT Display is switched on, the product marking is shown next to a loading bar which will be completed once all components have been started, as shown in Figure 1.



Figure 1. Loading screen

Immediately after loading, it will display the main interface, where you can see:

- The state of charge of the battery (soc, state of charge).
- The current date and time.
- The remaining range or charging time (if in charging mode).
- The current battery consumption in kWh. as shown in Figure 2.



Figure 2. Principal interface

### b. Icons.

On the right hand side of Figure 2, two icons can be seen, one referring to CAN communication, which will be green when CAN communication is present, and red when CAN communication is failing. Figure 3.



The second icon refers to the WiFi connection. It will appear in red if you are not connected to any network, in green when you are, and finally in red, but with a transparent centre when you are in configuration mode, indicating that the WiFi network configuration is available. Figure 4.



Figure 4. Loading screen

### c. Wifi hotspot configuration.

When the WiFi network icon is red with a transparent centre, it means that it is in configuration mode. We must connect to the WiFi network that is generated by a mobile phone. Figure 5.



Figure 5. Example of Display Wifi Network.

Once the connection has been made, go to the browser (Google Chrome, Safari, Firefox, Opera...) and in the address bar type: 192.168.4.1 then you will be redirected to the configuration portal. Figure 6.

In this portal you configure the time zone (+1 by default), the orientation of the display, where "-O" refers to the position of the button with respect to the screen. Finally, enter the SSID and password of the WiFi network to which you want to connect the display. When everything is ready, click on "Save".

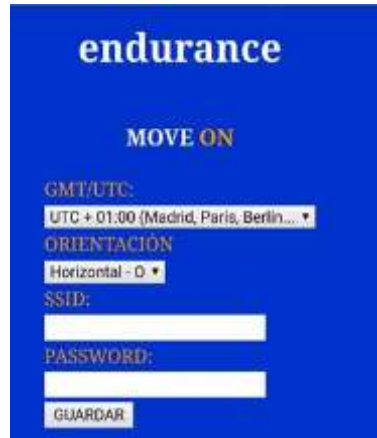

Figure 6. Example of access to the configuration portal.

#### d. Data verification.



Figure 7. Example of database graphs

Ask the manufacturer for the username and password to access the database of your device.

Once inside the window of your Logger you should be able to see the data being updated with a frequency of 10 seconds.

## 20. Charge.

The Polaris Lithium battery uses an external charger for charging. The charging interface also has a CAN Bus communication link that ensures optimal charging control. For more detailed information about charging and the functionality (e.g. indications and behaviour) of the charger, please refer to the charger's user manual. The Polaris Lithium battery is delivered with approximately 30% of charge, it is mandatory before its first use, to make a full charge in order to be balanced. After this first charge it is normal to observe that the charge does not reach 100%, after several full charges it will be balanced until it reaches 100%.

In general, the capacity demand of a lithium-ion battery is lower than that of an equivalent lead-acid battery. This is because it has fewer losses during use, better durability properties and the ability to charge faster and more frequently.

The Polaris Lithium battery can be charged at any time when the machine is not in use. Whenever the machine is not in use, it is recommended to connect the battery to the charger.

The Polaris Lithium battery is not damaged by short, intermittent charging. However, it is recommended to perform a full charge at least once a month to keep the battery balanced (see Maintenance sub-section).

The charging time depends on the output current of the charger, the nominal capacity of the battery and the current state of charge (SOC), as well as the internal temperature.

## 21. Storage.



**DANGER**

**ELECTRICAL HAZARD, we recommend storing batteries at a height between 15cm and 120 cm.**

Store in a cool, dry, well-ventilated place at a temperature between 0 and 40°C to preserve shelf life.

Indicate in the storage area that access should be strictly limited to personnel who are aware of the hazards and safety instructions.

<b>STORAGE PERIOD LESS THAN 2 WEEKS</b>	<ul style="list-style-type: none"><li>▪ No special care is required.</li><li>▪ During this period, the Polaris Lithium battery will not go into self-discharge protection mode.</li></ul>
	<ul style="list-style-type: none"><li>▪ Full charge is mandatory before storing.</li></ul>

<b>STORAGE PERIOD LONGER THAN 2 WEEKS</b>	<ul style="list-style-type: none"><li data-bbox="344 165 990 252">▪ Check the charge level every 6 months to keep the charge level above 50%. Recharge the battery to 100% if necessary.</li><li data-bbox="344 252 990 311">▪ (Higher ambient temperatures increase the discharge process).</li></ul>
---	--



## 22. Maintenance.

### a. Preventive.

#### i. Maintenance procedure.



**ATTENTION**

**Maintenance may only be carried out by qualified personnel with knowledge of high capacity batteries.**

<b>ONCE A WEEK</b>	<ul style="list-style-type: none"><li>▪ Check that the charging connections are not damaged.</li><li>▪ The charging connections have an IP21 rating, in environments with grade 4 contamination (conductive dust), it is necessary to check the cleanliness of the connector. In companies with grade 4 contamination, when the charging connector is not in use, it is recommended that it is protected with a specific plug for the connector.</li><li>▪ If necessary, clean the Polaris Lithium battery with a damp cloth. Never clean it under a jet of water or with a high-pressure jet.</li></ul>
<b>ONCE A MONTH</b>	<ul style="list-style-type: none"><li>▪ Leave the charger connected to the Polaris Lithium battery until it indicates that it is fully charged. Repeat this operation at least once a month to keep it balanced.</li><li>▪ After a period of time of incomplete charging and charging cycles, it may need to be balanced. This will ensure that all cells are fully charged and that you can enjoy the full capacity of the cells. This process is automatic and is done when necessary with the help of the charger, at the end of the charge cycle.</li></ul>

#### ii. Mode of protection.

The battery protects itself when it detects an abnormal parameter and goes into protection mode, disconnecting the DC output terminals and not allowing any power input or output. This may be an indicator that there is a problem, due to use of the

battery outside normal parameters, or as a self-protection measure to prevent deep discharge and damage to the battery.

In the event of a fault on the forklift, this will be displayed on the forklift's control panel (refer to the forklift's user manual).

In addition, a low state of charge (SOC) warning output is available to anticipate a deep discharge. This is a voltage free output with one normally open (NO) and one normally closed (NC) contact which should be connected to the machine.

## b. Corrective

### 1.1 Resolution of errors.

<p><b>BATTERY SHUTS DOWN UNDER LOAD</b></p>	<p><b>CAUSE:</b></p> <ul style="list-style-type: none"> <li>▪ Damaged cables.</li> <li>▪ Cell voltage too low.</li> <li>▪ Battery/cell temperature too high or too low.</li> </ul> <p><b>WHAT TO DO:</b></p> <p>Visually inspect the Polaris Lithium battery connections without disconnecting it from the forklift. If you suspect that the cables may be damaged, contact Endurance Motive S.A. service personnel. If no damaged cables are visually detected, proceed to the next step:</p> <p>Charge the battery in an indoor area between +5 °C and +30 °C. Wait for at least one hour (1 h) and use it again. If after this step, the Polaris Lithium battery does not switch on or switches on and off within one or two (1-2) minutes, contact Endurance Motive S.A. service personnel.</p>
<p><b>BATTERY DOES NOT CHARGE</b></p>	<p><b>CAUSE:</b></p> <ul style="list-style-type: none"> <li>▪ Damaged cables.</li> <li>▪ Battery/cell temperature too high or too low.</li> <li>▪ Defective charger.</li> </ul> <p><b>WHAT TO DO:</b></p> <p>Visually inspect the Polaris Lithium battery connections, without disconnecting it from the forklift. If you suspect that the cables may be damaged, contact Endurance Motive S.A. service personnel. If no damaged cables are visually detected, proceed to the next step:</p> <p>Try another charger and, if it still does not charge, go to the next step. Remove the charger and keep it indoors at a temperature between +5°C and +30°C for four to five hours (4-5 h), even longer if you suspect that the temperature is too high or too low.</p>

	Re-charge the Polaris Lithium battery in an indoor area between +5 °C and +30 °C. If it still does not charge, contact Endurance Motive S.A. service personnel..
<b>BATTERY DOES NOT TURN ON</b>	<p><b>CAUSE:</b></p> <ul style="list-style-type: none"> <li>▪ Electronic failure.</li> </ul> <p><b>WHAT TO DO:</b></p> <ul style="list-style-type: none"> <li>▪ Test the battery from the display button, then from the battery button.</li> <li>▪ If the ignition problem persists, contact Endurance Motive S.A. technical service personnel.</li> </ul>
<b>DISPLAY SCREEN DOES NOT SHOW DATA.</b>	<p><b>CAUSE:</b></p> <ul style="list-style-type: none"> <li>▪ Electronic failure Display.</li> </ul> <p><b>WHAT TO DO:</b></p> <ul style="list-style-type: none"> <li>▪ Disconnect the display from the battery and reconnect it via the cable connector. If the problem persists, contact Endurance Motive S.A. service personnel.</li> </ul>

## 23. Repairs.

If a Polaris Lithium battery needs to be repaired, Endurance Motive S.A. service personnel can replace some of the parts, but any damage to internal parts must be repaired at the Endurance Motive S.A. service centre.



**ATTENTION**

**Always contact Endurance Motive S.A. technical service when you suspect that the Polaris Lithium battery is damaged.**



**ATTENTION**

**Please read this manual carefully. Any damage to the battery resulting from failure to comply with the recommendations described in this manual will invalidate the use of the warranty.**

## 24. Warranty.

This limited warranty (“the warranty”) specified below applies to the family of POLARIS LITHIUM batteries (hereinafter, “batteries”) and accessories supplied by ENDURANCE MOTIVE, SA (“Endurance”) to the original buyer ( “the buyer”) directly or through an authorized reseller.

## **1. Purpose.**

The primary purpose of this warranty is to clearly define the issues relating to the warranty policy for POLARIS LITHIUM products.

The guarantee conditions indicated in this section are considered exclusive of any other condition or guarantee provided for in the Law.

## **2. Product and performance warranty.**

Endurance guarantees the Polaris Lithium batteries and accessories it supplies against any material or manufacturing defect and guarantees that they comply with the quality and performance advertised.

Endurance guarantees battery performance of at least 70% of nominal energy for 5 years from the date of invoice and/or 4,000 complete cycles, whichever comes first ("warranty period"), understood as a complete cycle. The sum of Ah of charge/discharge that is equal to the nominal amperage of the battery. The guarantee of the components that make up the battery will be 24 months.

The accessories supplied together with the battery such as Display, charge and discharge connection cables, and GPRS will have a warranty period of 12 months from the date of invoice ("the warranty Period").

The warranty entitles the buyer to have the battery and accessories repaired free of charge at Endurance's premises, including parts, labour and excluding transport costs incurred in making use of the warranty. In the event that the client requires that the repair be carried out at their facilities, the guarantee will not cover the displacements and diets that are produced by the application of the same.

If the battery has been exported outside the European Union, the warranty does not cover the transport costs incurred from the battery's location to Endurance's premises.

Replaced or repaired products will maintain the warranty period for the rest of the warranty period of the original product. In no case will the replacement justify the renewal or extension of the warranty period.

The guarantee will expire at the end of the term even if the Products have not been put into operation for whatever reason.

## **3. Conditions of enforceability of warranty.**

They will be essential conditions and constitute requirements for the enforceability of the Guarantees, which:

- a. The buyer undertakes to provide Endurance with all the information on the machine necessary to design the battery. This information is

- requested using the validation plan form, which will be signed by the customer as confirmation that the data provided is correct.
- b. Observe and follow the instructions for starting up and operating the products in accordance with the instructions provided by Endurance or Endurance designated suppliers.
  - c. The battery is operated under normal use in accordance with the specifications and manual provided by Endurance.
  - d. The battery is operated under normal use in accordance with the specifications and the current user manual published and provided by Endurance.
  - e. The ambient temperature during discharge must not fall below -10°C and must not exceed 60°C.
  - f. The ambient temperature while charging the battery must not fall below 0°C and must not exceed 55°C.
  - g. Endurance has been allowed to monitor the battery online in order to know its use at all times. If this monitoring is not possible, the Product and Performance Guarantee will be reduced to 2 years.
  - h. In case of sending the machine and battery outside European Union, before export, the buyer agrees to validate the correct operation of the battery with your machine. Endurance may ask the buyer for evidence of validation.
  - i. Our batteries comply, as far as necessary, with the legal requirements only within the European Union. The purchaser is solely responsible for compliance with legal or other regulations when using our batteries with their machine, and for performing the necessary tests to ensure compliance.

#### **4. Warranty exclusion.**

This limited warranty does NOT cover damage to products caused by one of the following activities:

- a. Improper transport, storage, installation or wiring by the buyer.
- b. Cleaning, adjustments or other periodic maintenance tasks.
- c. Modifications, alterations, disassembly, repairs or substitutions by personnel not certified by Endurance.
- d. Modifications required by changes in legislation.
- e. Non-compliance with the current user manual published and provided by Endurance.

- f. External influences, including unconventional physical or electrical stresses (current fault spikes, inrush currents, floods, fires, accidental breaks, etc.)
- g. Using an incompatible charger.
- h. What may be considered normal wear and tear due to use of the Product.
- a. Elements not manufactured by Endurance that will have those established by their manufacturers. Said Guarantees will be assigned to the buyer, who will remain as their beneficiary, without Endurance assuming any responsibility in relation to said elements from the date of the assignment, which will occur with the delivery of the Product.

At the order approval stage, the buyer must review and validate that the data provided for the battery design is correct and is necessary for the correct operation of the battery with the machine. Endurance does not guarantee errors in the dimensions, weight or operation of the battery with the machine because the data provided and validated by the customer in the validation plan are not correct or are insufficient.

The customer must review the delivery of the product immediately upon receipt. If, upon receipt of the Products, the client verifies their non-conformity due to apparent flaws, produced during transport, the client must sign the non-conformity of the delivery on the carrier's delivery note and the claim will be communicated as indicated in point 8 of this guarantee, immediately upon receipt. After this period Endurance will be exonerated from the damages produced during said transport.

Any claim or litigation will not entitle the Customer to suspend or, in any case, delay payment of the Products in dispute, or dispute or other supplies.

In any case, the liability of Endurance and/or distributors and/or any other intermediary of Endurance, is limited to the maximum amount of the sale price of the Product. Compensation for consequential damages is excluded.

In no case will it be compensated for consequential damages or for costs derived from the interruption in the operation of the Product (loss of profit).

## **5. Out-of-warranty policy.**

In the case of products out of warranty Endurance will offer a technical assistance service charged to the buyer, which will cover, among others, the costs of materials, laboratory, warehouse, transport, customs, analysis, management, business benefits, disposal costs (if necessary). In providing this service, Endurance will apply its rate policy.

## **6. About support products/parts.**

Support products/parts can be used new or refurbished, with similar or better performance than the defective products, with the Endurance warranty.

In the event that the products are no longer available on the market, Endurance may choose between (i) replacing them with others with equivalent functions and performance or (ii) returning the remaining annual value with the depreciation of the purchase price of the products during the Performance Guarantee period, as indicated in the following compensation scheme:

- CLASS I:60% of the purchase price from the date of initial installation to 24 months
- CLASS II :40% of the purchase price from 25 to 36 months
- CLASS III :20% of the purchase price from 37 to 48 months

For the above purposes, the purchase price shall be understood as the list price that the buyer actually paid for the acquisition.

## **7. Claims in use of the warranty**

Claims in use of the Guarantees will be notified to Endurance only by email to: [postventa@endurancemotive.com](mailto:postventa@endurancemotive.com) or to the distributor from whom the Product was purchased, within the Guarantee Period, accompanied by:

- a. Number and date of the delivery note or invoice for the product.
- b. The serial number of the corresponding product.
- c. Detailed description of the problem and under what circumstances it occurred.

Buyers who cannot contact the dealer from whom they purchased the product should contact Endurance by mail: [postventa@endurancemotive.com](mailto:postventa@endurancemotive.com).

## **8. Countries in which it applies.**

This guarantee covers incidents in the countries of the European Union, excluding all liability in the case of different countries.

## **9. Execution of the rights of the warranty.**

For any claim, you can contact us through our email [postventa@endurancemotive.com](mailto:postventa@endurancemotive.com). You must handle the claim as specified in point 8 of this warranty.

## **10. Entry into force.**

In general, the guarantees to which Endurance undertakes in this document will be valid from the date of invoice.

**endurance**<sup>®</sup>  
MOVE ON

**ENDURANCE MOTIVE S.A.**

[www.endurancemotive.com](http://www.endurancemotive.com)

Street la Bernia, 1

46529 Canet de Berenguer - Valencia - España

+ 34 96 134 30 44

All designs, text and images are the exclusive property of Endurance Motive S.A. Reproduction in whole or in part without the express consent of the owner is prohibited. Endurance is a registered trademark in the EU.